

Project	
Type	
Catalog #	

### Overview

This fully weatherproof unit is designed for use in areas of wet location. Designed to withstand direct contact with rain, this unit is corrosion-resistant and waterproof.

This unit is ideal in areas such as: car washes, store fronts, parking garages, kitchens, and chemical plants. Vapor Tite unit is capable of being hosed down for easy cleaning.



### Standard



### CONSTRUCTION

Exterior housing is designed for single piece, injection-molded, fiberglass/plastic combination blend. Neoprene gasket and stainless steel pressure locks ensure waterproof seal. Interior gear tray is heavy gauge die formed steel, which hinges to allow electrical raceway access while remaining attached to luminaire housing during installation and maintenance.

### ELECTRICAL

All units are furnished with UL Listed Class P thermally protected LED drivers. Other voltages are available upon request. Fixtures meet requirements for UL Luminaire Standard # 1598. All units comply with National Energy Standard. All units are UL certified damp location. Operates at a voltage of 120-277 (public spaces) with input voltage fluctuations of plus/minus 10 percent.

- Power Factor (PF) greater than or equal to 0.90 at full input power and across specified dimming range.
- Maximum Total Harmonic Distortion (THD) less than 20 percent at full input power and across specified dimming range.
- Operates for at least 50,000 hours at maximum case temperature and 90percent non-condensing relative humidity.
- Withstands Category A surges of 4 kV without impairment performance.
- Integral thermal protection that reduces the output power to protect the driver and light source from damage if the case temperature approaches or exceeds the driver's maximum operating temperature.
- 47 CFR 15. Complies with the requirements of the Federal Communications Commission (FCC) rules and regulations, Non-Consumer (Class A) for EMI/RFI (conducted and radiated).
- Class A sound rating.
- Restriction of Hazardous Substances (RoHS) compliant.

### WARRANTY & LISTINGS

- 5-year warranty of all electronics and housing.
- UL Certified for damp location
- 50,000 hours of L70 LED Life
- CRI >80 (>90 AVAILABLE UPON REQUEST)

### MOUNTING

Vapor Tite Unit is available with a stainless steel external hanging bracket. VT Series is watertight and must be drilled and sealed for each surface mounting or chain hanging application.

### DIMENSIONS

Max weight = 15lbs / 48" 32lbs / 96"

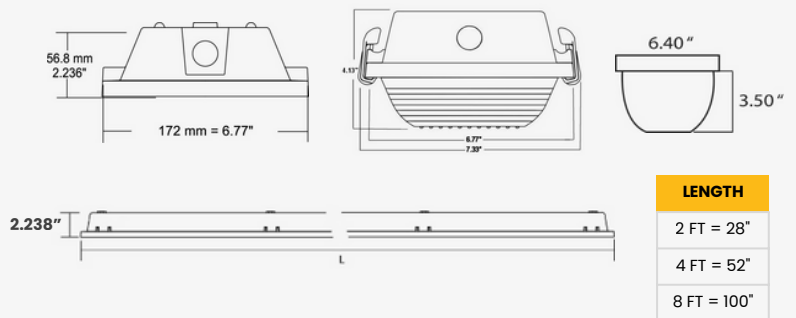

### ORDERING GUIDE

\* 0-10v low voltage dimming standard per fixture

\* Higher and custom lumen packages available upon request

	Series	Size	Lumens	CRI	Color Temp	Options
	CIT2 LED	2 = 2 FT	<b>2 FT</b>	8 = 80cri	30K - 3000K 35K - 3500K 40K - 4000K 50K - 5000K	EMER = Emergency driver REFS = Silver Reflector OCC-E = External Occupancy Sensor OCC-I = Internal Occupancy Sensor BILEVEL = Bi-level system SS = Stainless Steel Latch POLY = Polycarb lens FR = Frosted lens over LED boards
		4 = 4 FT	3166 (17W) 4350 (24W) 5470 (31W) 6452 (39W)			
		8 = 8 FT	3220 (17W) 4480 (24W) 5705 (30W) 6910 (37W) 8640 (48W) 11797 (70W)			

## CERTIFICATIONS

UL  
NSF  
NEMA4X  
IP65  
IP66  
IP67  
RoHS  
PSI 1500  
SLP Guardian Seal



**UL Listing:** File E363909  
**UL Recognized Components:** File E215168  
Components Tested and Certified by NSF International

**NEMA 4X**

Offers 34% more contact between the lens and the gasket.  
Guardian Seal™ is a unique combination of our Injection Molded lens features and high performance “poured in place” gasket.  
This provides the most advanced sealing system available.

