

Project	
Type	
Catalog #	

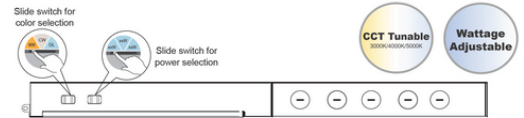

Application: Office, School, Conference room, Hospital, and more commercial spaces

Standard



SPECIFICATIONS

Model No.	BLPNL-2X2P-3W3CCT	BLPNL-2X4P-3W3CCT	BLPNL-1X4P-3W3CCT
Wattage	20W/30W/40W	30W/40W/50W	20W/30W/40W
Size	2'x2'	2'x4'	1'x4'
Lumens	2600/3900/5200 lm	3900/5200/6500 lm	2600/3900/5200 lm
Rated Input Voltage (V)	AC100-277V		
Light Source	SMD		
CCT	CCT Selectable: 3000K/4000K/5000K		
CRI	≥80		
Beam Angle (°)	120°		
Electrical Class	Class I		
Lumen Efficiency	130 lm/W		
Color Rendering Index	Ra>70		
Materials of Optics	PMMA (Lens)		
Working Temperature	-4 °F ~+122 °F / -20 °C ~40 °C		
Storage Temperature	-4 °F ~+149 °F / -20 °C ~ +65 °C		
Environment Location	IP 20 – Indoor Only		
Lifespan	> 50000H		
Lampshell	White		
DLC ID	PYKNODJH	PLW4UJM5	P2U165MP
Package Info	25.19" x 25.59" x 4.33"	49.61" x 25.59" x 4.33"	49.6" x 13.6" x 4.33"
PC / Master Pack	2	2	2
Weight (lbs)	14	25	14

PRODUCT DESCRIPTION

LED Back-Lit Panel is a direct lighting product with high lumen efficiency. It makes full use of all light and is more cost-effective compared with edge lighting LED panel lights. Adopt optical lens to offer a uniform light effect. With integrated iron plate, it provides great thermal management.

FEATURES

- Uniform light effect with optic lens
- Integrated iron plate design provides excellent thermal management
- Direct light design provides more even light distribution and longer lifespan
- High Lumen Efficiency: 130lm/W

OPTIONAL ACCESSORIES

Type	Image	Size
Surface Mount Kit		Available in all 3 sizes
Emergency Back Up		Available in 5W and 12W

ORDERING CODE DEFINITION

EXAMPLE: BLPNL-2X2P-3W3CCT

Product	Size	P	Power: 3W	CCT: 3CCT
BLPNL: LED Backlit Panel	2'x2'	P: DLC Premium Listed	20W/30W/40W	CCT Selectable: 3000K/4000K/5000K
	1'x4'			
	2'x4'			

DIMENSIONS

2x2

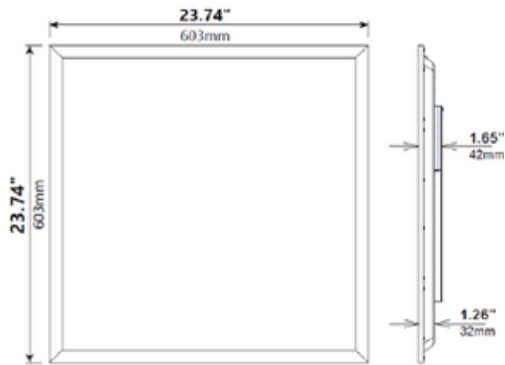

2x4

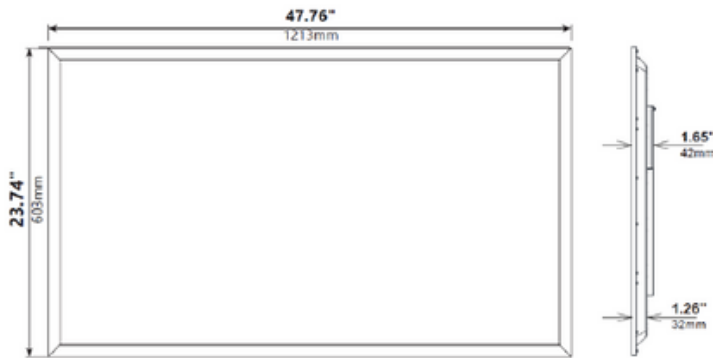

1x4



WIRING GUIDE

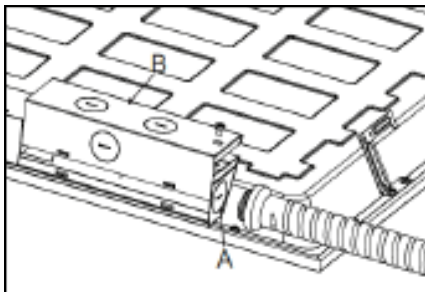

1. Remove the knock down hole on box by screwdriver.

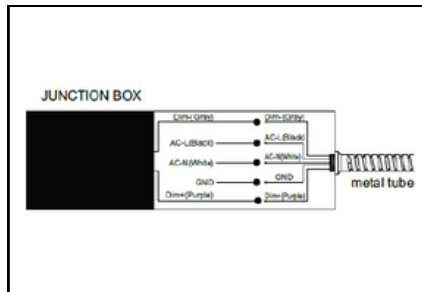

2. Connect the wire as the picture shows.

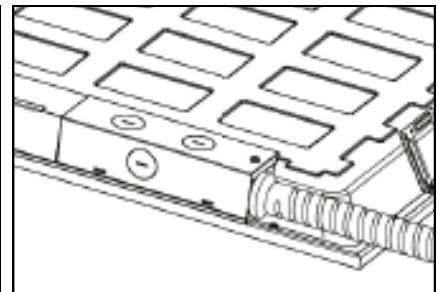

3. Cover the driver box and tighten it.

WATT AND CCT SELECTABLE

1'x4' and 2'x2'

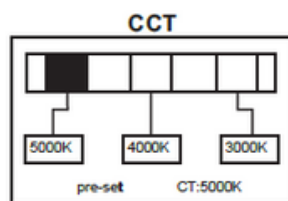
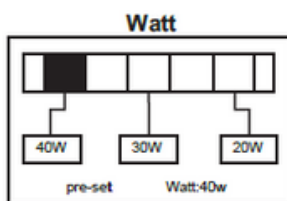

2'x4'

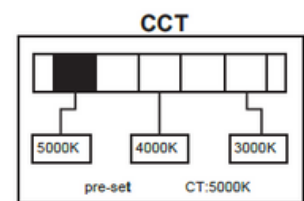
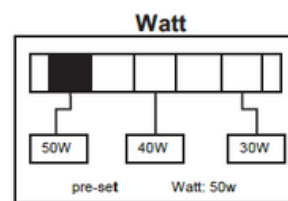

PRODUCT INSTALLATION

RECESSED

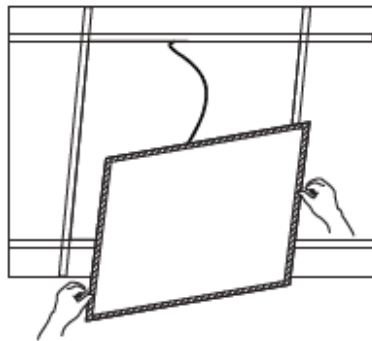
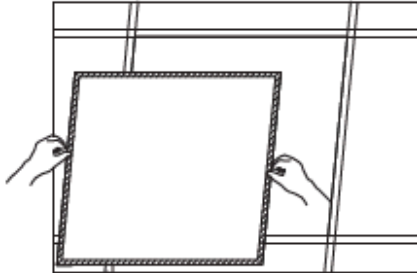

←
① Remove the ceiling plaster slab.

② Feed the main AC wire in driver terminal block respectively, connect the panel light and driver.

←
③ Fix the panel light into plaster ceiling.

④ Make sure the led panel light is firmly fixed, turn on the power.

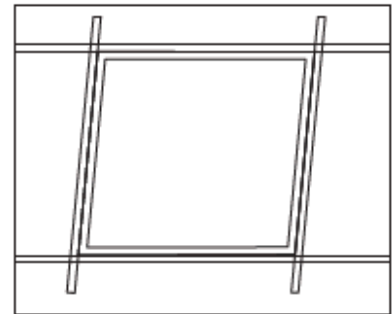
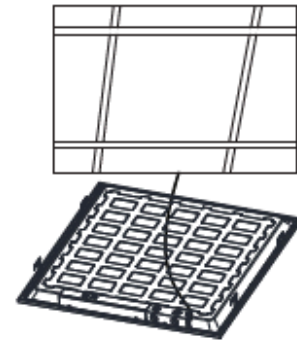

SURFACE MOUNTED

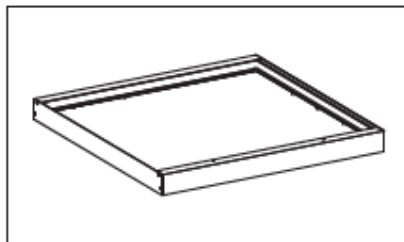
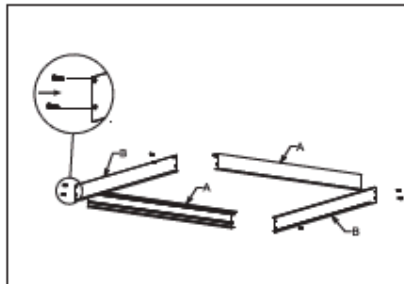

↑ ⑤ Make sure the frame and panel light are firmly fixed, turn on the power.

←
① Assemble the surface mounted frame and fix by screws.

② knock the plastic anchor into ceiling, fix the surface mounted frame on the ceiling by screws.

↓ ④ Fix the side frame back by screw.

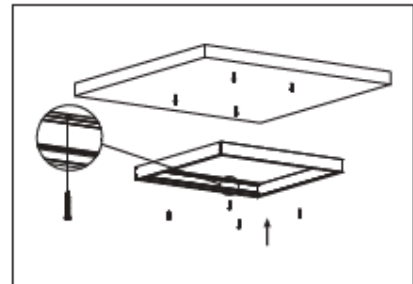
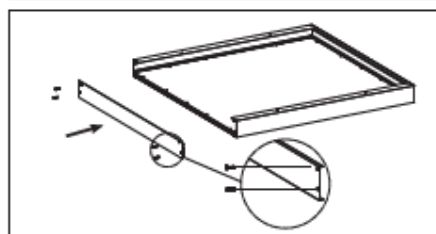

③ Unscrew the side frame then take out, connect the panel light to power supply, insert the panel light into the frame.

