

Project:	
Type:	
Catalog #:	



STANDARD



OPTIONAL



ILLUMINATION

- Long lasting, efficient, ultra bright white LED lamp heads.
- 1W (8 LEDs x 0.125) per head.
- High performance chrome-plated metallized reflector and plastic lens for optimal light distribution.
- Adjustable LED lamp heads provides optimal center-to-center spacing. High-lumen option available for increased center-to-center spacing.

ELECTRICAL

- Dual 120/277 voltage standard. Optional 120/347V (for Canada) and multi-tap 208/220/240 voltage available.
- Remote capacity standard.
- Charge rate/power "ON" LED indicator light and push-to-test switch for mandated code compliance testing.
- 3.6V long life, maintenance-free, rechargeable NiCd battery.
- Internal solid-state transfer switch automatically connects the internal battery to LED lamp heads for minimum 90-minute emergency illumination.
- Fully automatic solid-state, two rate charger initiates battery charging to recharge a discharged battery in 24 hours.

MOUNTING

- Surface mount via easy connect back plate, which fits most standard junction boxes and snaps into place making internal electrical connections.
- Top and side knockout for conduit applications.
- Suitable for wall or ceiling mount.

HOUSING

- Injection-molded, engineering grade, 5VA flame retardant, high-impact resistant, thermoplastic in white or black finish.

OPTIONS

- SDT: Self-diagnostic feature performs monthly, biannual, and annual tests to ensure reliable operation and meet electrical and life safety codes.
- HL: 12-LEDs per head provide increased center-to-center spacing.
- SPV: UL Listed for special voltage option.
- CSA: Tested to meet requirements of CSA C22.2 No. 141.10 standard for emergency lighting equipment.

WARRANTY / LISTING

- Five year warranty on all electronics and housing. Battery pro rated for five years.
- Meets UL924, NFPA 101 Life Safety Code, NEC, OSHA, Local and State Codes.
- UL (standard)/CSA (optional) listed for damp locations (0°C – 50°C).

DIMENSIONS

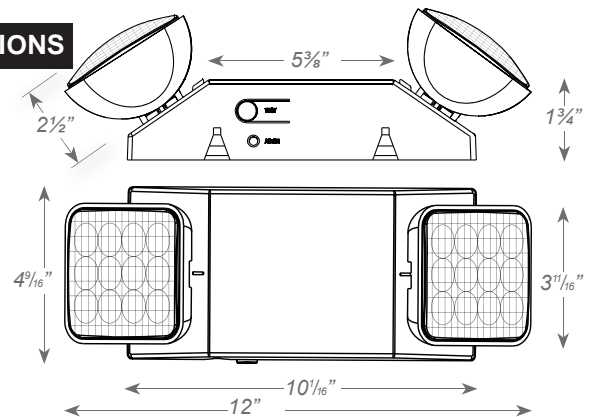

ORDERING INFORMATION

Sample Part Number: **LEDR5HO**

MODEL	HOUSING COLOR		OPTIONS	
LEDR5HO	BLANK	White	SDT	Self-Diagnostics
	B	Black	HL	High-Lumen
			SPV	208/220/240 volt, 50/60 Hz ¹
			CSA	120/347V, 60Hz

¹ Not available with SDT options.

Project:	
Type:	
Catalog #:	

ELECTRICAL INFORMATION

CATALOG NUMBER	INPUT WATTS (W)						INPUT AMPS (A)					
	120V	277V	347V	208V	220V	240V	120V	277V	347V	208V	220V	240V
LEDR5HO	2.1	2.1	-	2.8	3.6	3.3	0.025	0.012	-	0.025	0.029	0.025
LEDR5HO-SDT	1.9	1.9	-	-	-	-	0.020	0.010	-	-	-	-
LEDR5HO-CSA	3.0	-	3.0	-	-	-	0.025	-	0.009	-	-	-

CENTER-TO-CENTER SPACING GUIDELINES

For reference only.



1	0.2	0.3	0.5	0.4	0.4	0.5	0.6	0.8	1.0	0.8	0.9	0.8	0.4	0.2	0.2	
2	0.3	0.5	0.7	0.8	0.9	0.8	0.9	1.0	1.1	1.4	1.1	0.8	0.5	0.3	0.2	
3	0.4	0.7	1.0	1.0	1.1	1.1	1.1	1.3	1.4	1.1	0.9	0.9	0.7	0.5	0.2	
4	0.5	0.7	0.9	1.1	1.2	1.2	1.0	1.1	1.1	1.0	1.1	0.8	0.6	0.3	0.2	
5	0.5	0.7	0.8	0.8	1.0	1.1	0.8	0.8	1.0	0.9	0.6	0.5	0.4	0.3	0.2	
6	0.4	0.5	0.7	0.7	0.8	0.8	0.6	0.5	0.6	0.5	0.4	0.4	0.3	0.2	0.2	
	7	6	5	4	3	2	1	0	1	2	3	4	5	6	7	8

Meets NFPA 101 Requirements for: 10' center-to-center spacing - 3' path of egress 1' from the wall- 7 1/2' mounting height.

REMOTE LAMP COMPATIBILITY

MODEL NUMBER	BATTERY	REMOTE CAPACITY	COMPATIBLE REMOTE HEAD FAMILY													
			RHLed			RH16LED	RH16		RH		RHR		SRH		SRHLED	
			3.6V	9.6V	MV		6V	12V	6V	12V	6V	12V	6V	12V		
LEDR5HO	3.6V	3W - 4W	X		X	X										